



OPERATIONS MANUAL

FOR THE PNEUMATIC-HYDRAULIC RIVETING
TOOL

Air Power 1

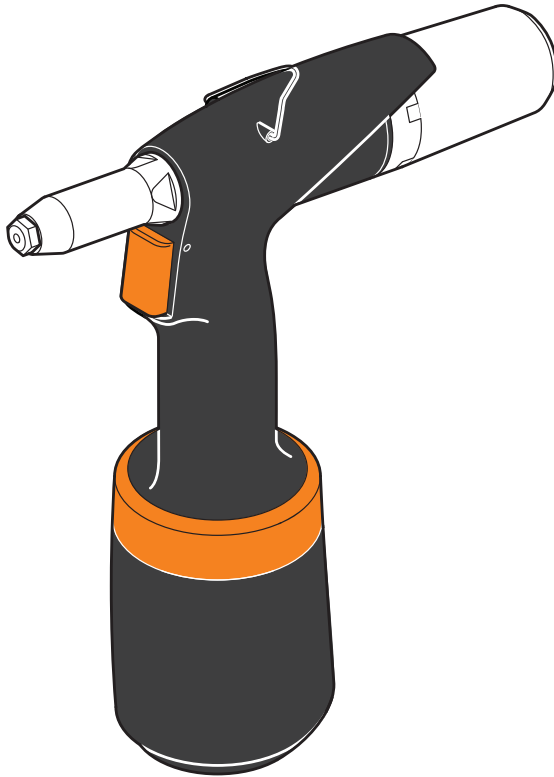



TABLE OF CONTENTS :

1. GENERAL SAFETY INSTRUCTIONS AND PRINCIPLES 	3
2. DESCRIPTION OF THE TOOL	5
2.1. Basic dimensions	5
2.2. Technical data	6
2.3. Range of usage	6
2.4. Tool operation	6
3. MACHINE MAINTENANCE	9
3.1. Daily maintenance	10
3.2. Weekly maintenance	10
3.3. General maintenance	12
4. SPARE PARTS	13
4.1. Ordering	13
4.2. List of expendable parts	13
5. STORAGE	13
6. COMPLETE TOOL EQUIPMENT	14
7. OPERATIONS AND WARRANTY CONDITIONS	14
7.1. Operation conditions	14
7.2. Warranty condition	15
7.3. Guarantee form	16

1. GENERAL SAFETY INSTRUCTIONS AND PRINCIPLES



ATTENTION! Read all instructions and principles carefully. Every person installing, operating or maintaining the tool must be first thoroughly acquainted with this operations manual and is obliged to adhere to the following safety instructions and principles:

- The tool must not be used for other purposes than those for which it was designed.
- The tool must not be used in a different manner than that recommended by the manufacturer
- Any alterations of the tool, its accessories or spare parts remain in sole responsibility of the customer. After agreement the manufacturer provide technical support in designing and making additional alterations.
- The tool must be kept in top condition and regularly tested for damage and proper operation. The tool must be repaired only by an authorized technician or by a person trained by the manufacturer or supplier. Should you have any demand for training, please contact your sales agent.
- The tool must always be operated in accordance with respective sanitary and safety regulations.
- All queries regarding proper and safe operation of the tool should be addressed to your sales agent.
- Safety principles that must be adhered to in connection with operation of this tool must be known to all workers who operate the tool
- When handling the tool take extra care to avoid unwanted activation and possible injury.
- The tool must be during any kind of maintenance or repair (does not apply to replacing nose-pieces and emptying the mandrel container) disconnected from the source of compressed air.

- Before operating the tool always take up firm posture and steady position.
- It is necessary to prevent break-away shanks endangering safe operation of the tool.
- Never aim with the tool at another person.
- Always check that the vent holes are not blocked or covered and that the supply hose are in good condition.
- Working pressure must not exceed 0,7 MPa.
- Oxygen or other flammable gasses from pressure cylinders must not serve as a driving agent.
- When operating the tool it is recommended to use safety glasses and utility gloves.
- If the continuous cycle of riveting exceeds 8 hours per day, it is recommended that the operators use ear protectors.
- When working with the tool the operator must not have loose parts of wear as e.g. a tie, long hair, jewellery etc. to avoid getting caught by the tool.
- Same safety instructions apply for persons standing close to the tool.
- Avoid unnecessary contact with the hydraulic fluid to prevent possible allergy reaction of the skin.
- The tool is not designed for explosive environment.
- After the service life, discard the tool according to the Disposal Act no. 185/01 Coll.

2. DESCRIPTION OF THE TOOL

2.1. Basic dimensions

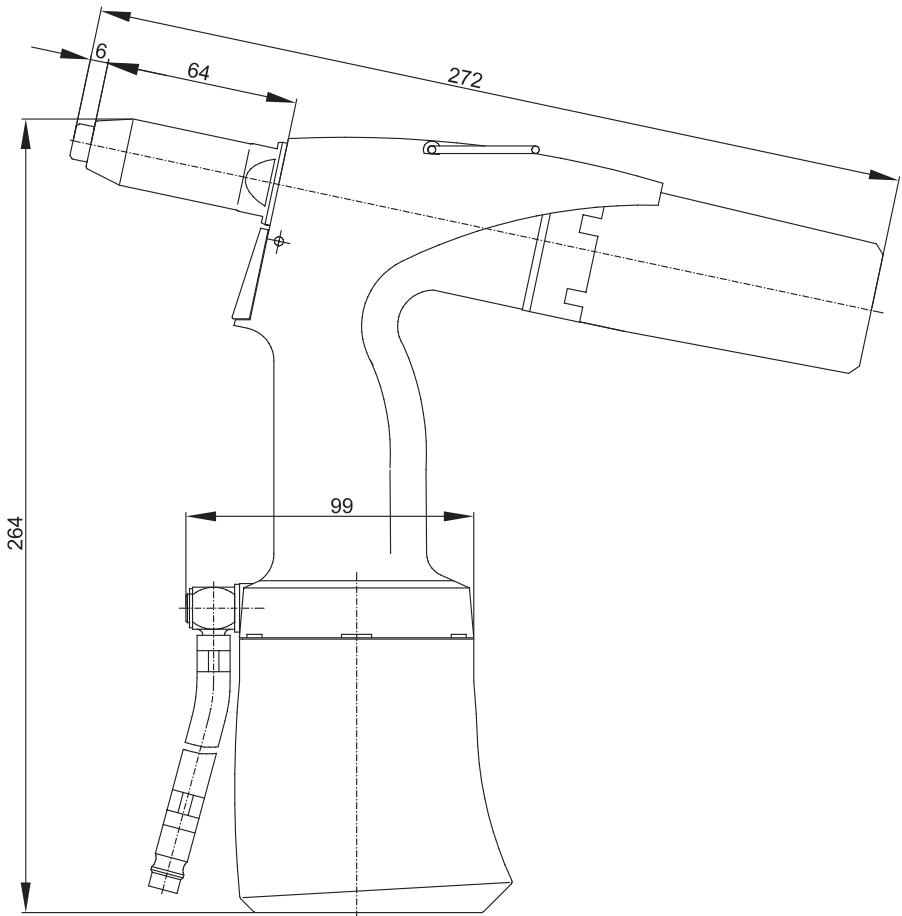

2.2. Technical data

weight	1,25 kg
working pressure	0,5-0,7 MPa
stroke force at 0,6 MPa	7,3 kN
air consumption	1,5 l / stroke
stroke	17 mm
height	264 mm
length	272 mm
width (over the angle valve).....	99 mm
front nozzle diameter	22,5 mm
front nozzle length	64 mm

2.3. Range of usage

The pneumatic-hydraulic tool is designed for riveting with blind rivets:

Al (aluminium)	St (steel)	Rv (stainless steel)
Ø 2,4	Ø 2,4	Ø 2,4
Ø 3,0	Ø 3,0	Ø 3,0
Ø 3,2	Ø 3,2	Ø 3,2
Ø 4,0	Ø 4,0	Ø 4,0
Ø 4,8	Ø 4,8	Ø 4,8
Ø 5,0	Ø 5,0	Ø 5,0

2.4. Tool operation

The manufacturer equipped the tool with an nose-piece /figure 1 – pos. 1/ for a rivet Ø4,8-5,0. Riveting with blind rivets of different diameters (further on referred to as BR) requires use of appropriate nose-pieces /figure 1 – pos. 1/ that are located in the accessories casing of the tool.

Replacement of nose-pieces: Connect the tool to the source of compressed air, depress the trigger and screw out the nose-piece /figure 1 – pos. 1/ with a spanner no. 12. Screw on a new nose-piece /acc.to the chart/ and tighten it. Now you can release the trigger of the tool.

Recommended numbers of nose-pieces with respect to rivet diameters (does not apply for all types of rivets)

rivet Ø	marking of nose-piece
4,8 - 5,0	nose-piece no. 5
4,0	nose-piece no. 4
3,0 - 3,2	nose-piece no. 3
2,4	nose-piece no. 2,4

The tool is equipped with revolving air supply /fig. 1 – pos.4/ which enables manipulation with air supply before as well as during tool operation, air hose does not obstruct riveting in any position.

The tool is equipped with a trigger /fig.1 – pos.3/. Released trigger enables pushing a rivet into the tool (the tool is ready for riveting), depressing the trigger shall fix the rivet.

The tool is equipped with a multifunctional mandrel container /fig.1 – pos.5/ which has the following three positions (see fig.1/1A):

Position 0 – mandrel container removed

Position 1 – mandrel container mounted, suction is switched off

Position 2 – mandrel container mounted, suction is switched on

1) Mounting the mandrel container:

Push the mandrel container /fig.1 - pos.5/ into the ring relief /fig.1 - pos.6/ end-to-end, thus you depress the arrestment element, and turn to position 1 or 2. The mandrel container shall thus be in place. Suction shall initiate in position 2. Silicone hood of the mandrel container /fig.1 - pos.7/ can be turned to let the compressed air out in suitable direction (e.g. offward the operator)

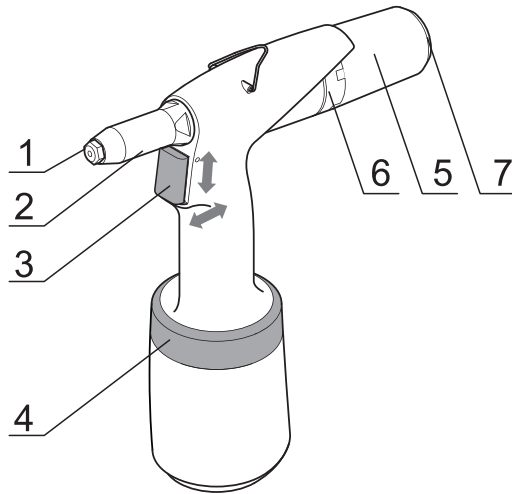

Fig. 1

2) Removing the mandrel container:

Turn the mandrel container end-to-end to position 0 and pull it out fig.1/1A of the ring relief. The suction shall thus switch off

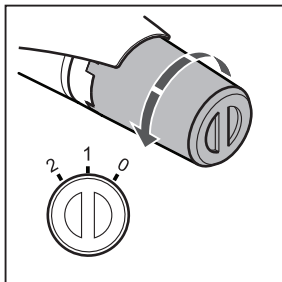

Fig. 1/1A

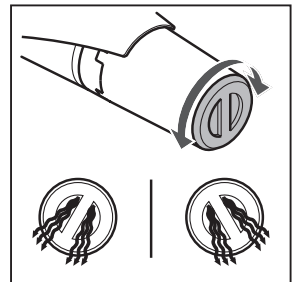

Fig. 1/1B

The tool can be operated in the two following manners:

1) with the mandrel container removed in position 0:

Suction switches off by turning and removing the mandrel container /fig.1 - pos.5/. Insert BR into the riveting tool through the nose-piece hole. Depress the trigger to move the jaws offward the BR head. The movement ends when reaching max. stroke, correct BR with respect for material gauge shall tear off the shank (riveting) for one stroke of the tool. Releasing the trigger shall return the jaws to initial position and released torn-off shank can be removed from the nose-piece by tilting the tool. /fig.1 - pos.1/

2) with the mandrel container mounted in position 1:

Mounting and turning the mandrel container /fig.1 - pos.5/ to position 1 shall arrest it. Insert BR into the riveting tool through the nose-piece hole. Depress the trigger to move the jaws offward the BR head. The movement ends when reaching max. stroke, correct BR with respect for material gauge shall tear off the shank (riveting) for one stroke of the tool. Releasing the trigger shall return the jaws to initial position and the released torn-off shank can be transported into the mandrel container by tilting the tool /fig.1 - pos.5/.

3) with the mandrel container mounted in position 2:

Suction switches on by turning the mandrel container /fig.1 - pos.5/ to position 2. In this position the suction holds BR in the nose-piece /fig.1 - pos. 1/ which enables riveting in any position without danger of BR falling out of the nose-piece of the tool. Depressing the trigger shall perform riveting. Releasing the trigger shall transport the shank into the mandrel container. If the mandrel container is full with shank to appx. 70%, it is necessary to remove and empty it in a specified manner (e.g. to a prepared container). Overfill of the mandrel container may result in failure of the riveting tool.

3. MACHINE MAINTENANCE During maintenance the tool must be disconnected from the source of compressed air !!!

3.1. Daily maintenance

Daily, before starting work, apply several drops of lubricating oil (we recommend hydraulic oil HYPIN AWHM 32 CASTROL) into the air inlet of the tool, on condition there is no lubricating device connected in the air distribution. If the tool is in continuous operation, it is necessary to disconnect the air hose from the main air supply and lubricate the tool every 2 or 3 hours.

Check the tool for air leakage, if necessary replace damaged hoses and clasps.

If the pressure regulator is not equipped with a filter, blow through the air hose before its connection to the tool in order to get rid of impurities and water. If the pressure regulator has a filter, dry it out.

Check whether the fixed nose-piece corresponds to the BR diameter and that all screw threads and joints are tightened properly.

Check whether the holes for passage are really empty. If it is not so, it is necessary to remove the damaged part, clean the hole or replace the damaged part with a new one, see paragraph 3.2 weekly maintenance.

3.2. Weekly maintenance

Cleaning and replacement of worn or non-functional parts.

Disassembly:

Disconnect the tool from the source of compressed air, unscrew the adjustable front nozzle /fig.2 - pos.2/ by means of a spanner no. 23, set the spanner no.15 onto the clamping sleeve /fig.2 - pos.3/, set the spanner no. 17 on the backnut /fig.2 - pos.9/ and loosen. Unscrew the clamping sleeve, replace the jaws /fig.2 - pos.4/ and jaw pusher /fig.2 - pos.5/. Then screw the clamping sleeve back on and shift out the suction pipe /fig.2 – pos.7/ by means of short connection of the tool to compressed air. The suction pipe can be removed after disconnection of compressed air and unscrewing the clamping sleeve. All used threads are right-handed. Clean the dismantled parts thoroughly and check them visually, especially the following:

- 1) Jaws /fig.2 – pos.4/ - if worn or damaged, replace it, if dirty, clean it with a wire brush.
- 2) Nose-piece, jaw pusher /fig.2 – pos.1,5/ - for wear of functional surfaces of the taper.
- 3) Completed tube /fig.2 - pos.7/ - blow air through, if not clear (congested with shanks of BR), replace it.
- 4) „O” ring / fig.2 - pos.6/ - if damaged, replace it with a new one.
- 5) Adjustable front nozzle / fig.2 - pos.2/ - check for damage of the internal surface ($\varnothing 18$).
- 6) Scraper ring /fig.2 - pos.8/ - if damaged or worn, replace it with a new one.
- 7) Mandrel container / fig.2 - pos.10/ - if the mandrel container or its bottom are worn or damaged, replace them with new ones, otherwise there is danger of the torn-off shank popping out.

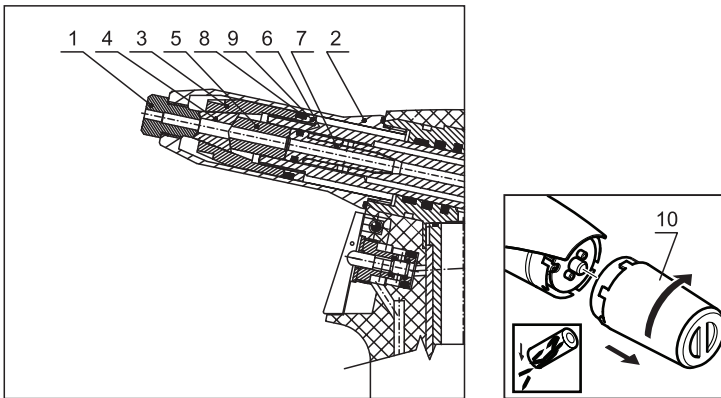

Fig. 2

Assembly:

Mount the parts (see par. disassembly) in a reverse order. On the outer surface of the jaws /fig.2 – pos.4/ apply a drop of lubricating oil (we recommend hydraulic oil HYPSPIN AWHM 32 CASTROL), apply thin layer of plastic lubricant MOGUL LV 2-3 to the suction pipe and "O" ring /fig.2 – pos.7,6/. Basic set-up of the jaws is performed as in fig. no. 3.

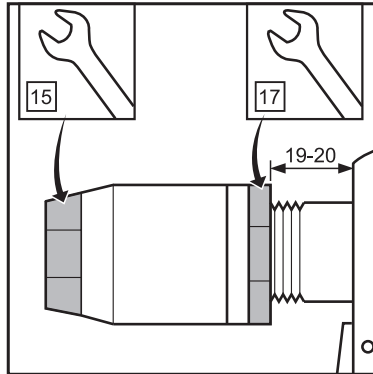

Fig. 3

3.3. General maintenance

General maintenance should be performed after every 500 000 strokes or once every three years. The whole tool must be disassembled and all seals and worn parts must be replaced. This repair may be carried out by an authorized technician only or a person trained by the manufacturer or supplier.

4. SPARE PARTS

4.1. Ordering

Order the spare parts exclusively from the manufacturer or from your sales agent.

The order must contain:

- a) tool serial number**
- b) number of ordered part**
- c) number of pieces**
- d) name of your company and precise address**
- e) your tax identification number and identification number**

4.2. List of quickly expendable parts

Nose-piece 2,4	D-06400124
Nose-piece 3,2	D-06400132
Nose-piece 4	D-06400140
Nose-piece 5	D-06400150
Clamping sleeve	D-1100100
Set of jaws	D-06301412
Completed tube	S-1100500
"O" ring 7,1/1,6	N-2103700710160
Adjustable front nozzle	D-1100600
Scraper ring	D-1100300
Nut HP	D-1100400
Mandrel container with silicone hood	S-1201401
Jaw pusher	D-1100200

5. STORAGE

The pneumatic-hydraulic tool embedded in a shipping container must be stored in environment with relative humidity to 70% and temperature ranging from +5oC to +40oC, without aggressive evaporation of salts, acids and caustics..

6. COMPLETE TOOL EQUIPMENT

Replaceable nose-pieces located in a plastic reservoir (2,4; 3; 4), Operations manual, Guarantee form.

We recommend the customer to check completeness according the the above stated list.

7. OPERATIONS AND WARRANTY CONDITIONS

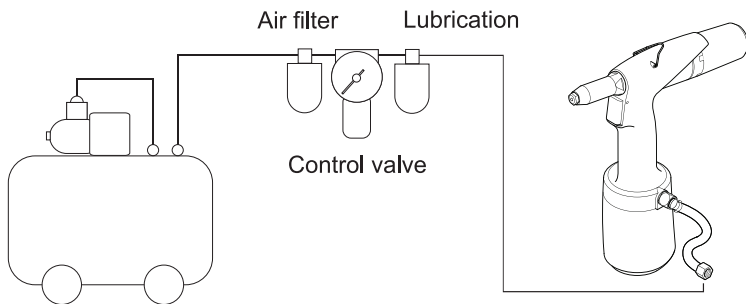

For reliable function of the tool we recommend to use treated compressed air.

Treated compressed air means compressed atmospheric air bare of solid particles and water, reduced to required pressure and lubricated with anti-corrosive oil.

7.1. Operation conditions

Operation data: For reliable and safe function of the tool it is necessary to adhere to instructions and principles stated above. Immediately before the tool there must be a regulation valve set to maximum outlet pressure of **0,7 MPa**, air filter and lubrication in the circuit of compressed air. Final level of exposure to noise standardized for regular working day of 8 hours is $L_{Aeq,8h} = 85$ dB, against which during continuous and long-term operation it is recommended to use ear protectors. Average total weighted level of vibration acceleration is $L_{ahv,8h} = 126$ dB re 10^{-6} ms^{-2} . Average total weighted effective value of vibration acceleration is $a_{hv,8h} = 1.995 \text{ m/s}^2$. The trigger enables safe control of the tool with a force max. $10 \text{ N} < 50 \text{ N}$ without releasing the grip-handle according to the health regulation.

7.2. Warranty condition

For the warranty period the customer must not perform any alterations other than those permitted by the manufacturer, see paragraph 2. 4, 3. 1, 3. 2. Other non-detachable parts are secured with paint. In case of neglecting this protection the manufacturer shall not admit possible warranty repairs. To admit warranty repair the customer must submit confirmed warranty certificate of the tool, Certificate of quality and completeness or proof of purchase. The warranty period is 24 months from the day of purchase confirmed in the Warranty certificate if the purchase contract does not state otherwise.

8. QUALITY CERTIFICATE OF AIR POWER 1 TOOL

The provisions of the Product Technical Specifications Act 22/97 Coll. including the respective Decree of the Government specifying individual products criteria apply to the hydraulic/ air- operated riveting tongs. Under this Act, the product was tested by the accredited testing laboratory for the hand-operated tools of State Testing Laboratory No. 214 VVUÚ Ostrava-Radvanice. When testing the product pursuant to Governmental Instruction No.24/2003 Coll. Coincident with direction EU 98/37/EC, ČSN EN 792 – 1 and the connected paragraphs of Decree No.48/82 Coll. issued by the ČÚBP, the laboratory has found out that the product meets the above-mentioned requirements.

The producer declares the meeting of the legal obligations including the determined quality of the product by the written **DECLARATION OF CONFORMITY** attached to each dispatched shipment.

The warranty applies since the undermentioned date filled in warranty certificate for the period of 24 months on condition of adherence to:

1. General safety principles and instructions
2. 4. Instructions for tool operation
3. 1. Daily maintenance
3. 2. Weekly maintenance
5. Storage
7. Operation and warranty conditions

The warranty does not apply to quickly expendable parts stated in paragraph 4.2.

